

Variable-pitch Jack Plane

BY JOHN WILSON

This jack plane can be easily set to work at 45° for rough work or 52° for smoothing chores.

The story of this plane goes back 20 years to a chance encounter I had with a Cecil Pierce jack plane. Pierce was a planemaker in Maine who made beautiful planes for more than 50 years. Just a one-man operation, an avocation really, for the love of the craft. I saw the plane while on the road in a shop where I was teaching and its shape captivated me. I drew its plan. I was to the point of asking if I might buy it. I was smitten.

That experience surfaced recently when a group of friends with whom I conduct a tool-making session asked for something different. How about a jack plane? I thought of Pierce's plane.

The Design

There are three basic parts to this plane: the wood body, the cutter and the adjustment mechanism. The Pierce plane body was what started the venture, and was easiest for a woodworker to make. The design copies his work which is gratefully acknowledged ("Fifty Years a Plane Maker and User," by Cecil E. Pierce (Monmouth)). What is different is the method of construction and the blade-holding cap. Instead of starting with a single wood block, I start with three: one core and two side boards.

The blade is made from O1 tool steel available from mill supply catalogs in an 18" length, which is enough for three blades, for about \$20. Two reasons exist



Jack of all trades. Jack planes can be used for both roughing and smoothing chores. This shop-made example allows you to change the pitch of the iron. Low for rough work. High for fine.

for making your own blade. One is being able to make exactly the kind of blade needed for the plane. The second is finding out how blades are made. I incorporate blade making in all my tool workshops. You might be interested in reading about this in "Making a Spoke-shave," *Popular Woodworking*, October 2007 (#164). I have heard from students that the blade forming and hardening is an epiphany.

The third element is the blade-adjustment mechanism. For hundreds

of years, shop-made planes had a wedge holding the blade. Then in the period from 1875-1900, a series of developments occurred resulting in the modern plane. The ability to advance and retract the blade by a screw mechanism rather than by tapping a wedge won over the market.

What follows is a description of the three parts of the plane: the blade, the body and the adjustable pressure cap.



Makeup. The elements of a jack plane with double-screw adjustment: Razee plane body, cap with holding and adjustment screws, blade with rest button, and 52° wedge for optional smoothing plane pitch.



Parts. Parts of the jack plane: Handle with 3/4" holes prior to cutting, blade, cap parts, core block and sides, angle pattern, lead screw and thumb nut.

See for yourself if a shop-made plane that looks good, adjusts easily and cuts well is something you can make.

The Plane Iron

The 1/8" x 2" x 5 1/2" plane iron is cut from O1 tool steel. It makes a fine blade that has parameters for hardening and tempering well-suited for woodworking.

Tool steel comes in an annealed state softer than it will be later after heat treating. You can saw, drill and file it as it has a Rockwell 45C hardness. Above Rockwell 55C such tools cannot cut steel. However, it is not as soft as mild steel, so get a new blade for your hacksaw before attempting it.

The main screw is a 3/8" threaded post with a brass knurled nut. You need to make a slot in your blade by drilling two 25/64" holes, not quite touching, joined by filing to complete the slot. Another tool for enlarging a hole is called a rotary file (Reid Supply #GAR-60020; \$6.12), which is a 1/4" bit with carbide burrs along its side to enlarge a hole. The hole for the stud, called a rest button, is drilled into the blade at this time using a 3/16" drill.

The tombstone shape of the top end is filed after grinding to smooth and ease its edges. The cutting end is ground to 25°. Do not be alarmed by producing some blueing, which is indicative of overheating the steel in ordinary sharpening activities. The whole cutting end will be heat treated.

One of my favorite tools for sharpening blades is a 4" x 36" belt sander. I save my belts after working wood to use

them for steel. A new belt works best, but you can get one blade sharpened on a used belt. Use the belt sander after using a grinding wheel as it will give a perfectly flat surface. The belt is much less likely to blue the blade than grinding. Safety point: Clean out any wood dust before doing this to avoid sparks causing a fire.

Heat treating a tool steel blade is a mysterious venture for the uninitiated, so take this opportunity to lift the veil. First, it is helpful to know some hardness/brittleness characteristics of the O1 steel. Soft and workable is what the annealed state is at Rockwell 45C. The crystalline structure of the steel is changed by heating above 1,450° Fahrenheit (F) followed by an oil quench. The heating is done by either a welder's torch or a handy propane torch on which the flame is large enough to heat a 2"-wide blade. (BenzOmatic torches series JT, BT and TS all have a brass regulator valve with a side-mounted burner tube that delivers enough flame to do the job.



Blade beginnings. Making the blade begins with a 3/8" slot and hole for the rest button. The 25° angle is ground and the top rounded.

"(T)be rule in the trade being that all which the plane passes over is joiners' work."

— Henry Mayhew (1812-1887)
The Morning Chronicle, July 11, 1850

A "pencil point" torch does not deliver enough heat. MAPP gas delivers a hotter flame than propane.)

How do you know you have heated the steel to the right temperature? The end should glow medium red when viewed in shaded light, not full sunlight. The quench is a full immersion, rapidly dipped to avoid warping the steel. The oil can be motor oil, new or used. However, soy oil is better, as it does not smoke.

The blade has a gray appearance where it is heated, and the steel is hard to Rockwell 75C. If you have any concern about whether or not you have the heat and quench right, run a file lightly along the edge. Where it is still annealed, the file will bite into the steel. Where it is hard, it will glide over it.

Along with hardness goes brittleness. Rockwell 75C steel will actually shatter when struck by a hammer. Tempering a blade reduces hardness and restores the necessary toughness. The proper hardness range is around Rockwell 62C. A second operation, called tempering, to moderately heat and slowly cool the steel, will accomplish this.

When you purchase tool steel, the wrapper often gives you information on tempering temperature with resulting



Homemade furnace. Harden the cutter using a torch and furnace made of nested tin cans. Quench when red hot. A 2" x 2" piece of sheet metal with a hole (slid over the end of the torch) protects the plastic from heat.



Toast. Temper in toaster oven for one hour at 350° F. This restores necessary toughness to the tool steel while resulting in Rockwell 62C hardness.

hardness. The Starrett brand O1 steel indicates heating it to 300-350°F for one hour will result in 62C-64C hardness; 400-450°F for one hour results in 58C-60C hardness. Anything over that will be too soft to hold an edge. A kitchen toaster oven or household oven works. If you have any doubt on the accuracy of the oven's thermostat, purchase an oven thermometer (less than \$5) to be sure. Set the blade in the oven for one hour then allow it to air cool.

Now that the blade is heat treated you can finish sharpening the bevel and lapping the back. The rest button, which engages the blade adjuster, is now ground at a 15° angle to provide a landing for the adjustment rod. It is ground flush with the back of the blade. A drop of cyanoacrylate (CA) glue will set it permanently in place.

The Wooden Plane Body

The wood for this plane can be selected from a range of hardwoods. Beech was traditionally used in Europe, but hard maple is my first choice.

The challenge for any planemaker is accurately forming the throat. The two elements are the angle of the iron, and the opening in the sole, called the mouth. Achieving accurate angles within the throat, and doing so without going beyond any of the respective surfaces, is the challenge. Besides cutting into a single block of wood, two-piece and three-piece plane body methods are possible.

A two-piece or three-piece plane body eliminates many difficulties in making the throat. Making a two-piece plane is described by Bud McIntosh (*WoodenBoat*, March 1986). The

three-piece plane is described by James Krenov in "The Fine Art of Cabinet Making" (Sterling). In both cases, the plane throat is cut and the body is reassembled with glue.

The drawing on page 52 shows you the basics. The bedding angle is 45°, the forward face is 60°. The width of the pocket is the blade width plus a small amount for lateral adjustment. Accurate dimensioning of the core block provides the 1/32" used by Pierce.

Assemble the Three-piece Body

Starting with a core block that's 2 1/32" x 2 1/32" x 12 1/2", draw a line 3 5/8" from the end. Ahead of this line mark and cut a 60° angle, and after it a 45° sloped block. These surfaces must be square and flat. A small flat is made on the 60° block 3/16" back from the sharp edge. The two side pieces are 5/16" x 2 1/32" x 12 1/2".

An alignment board will aid in glue-up. A scrap of 1/4" x 2 1/2" x 12 1/2" plywood is waxed. Mark on this a line square across at 3 3/4" from one end. A second line 5/16" away from the first defines the opening of the throat. Prepare for glue-up by clamping the two core blocks to the alignment board. Spread glue on all surfaces avoiding the throat opening on each side board. The alignment board allows you to keep the right throat opening, and the even alignment of the core and sides.

Two 3/16" x 1/2"-long dowels are driven



Three-piece body. By dividing the plane box into three pieces, the angles of the blade pocket can be easily and accurately made: a 45° bedding angle, a 60° front angle and one small 90° cut in the front block.

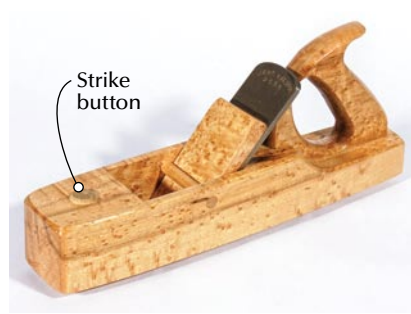

Jack plane with wedge and retainer dowel pin. This is a simple yet effective jack plane mechanism. Note also the wood strike button in the fore block.



Dowel both sides. Two 3/16" pins on both sides will prevent movement under pressure. While two clamps hold the core blocks to the alignment board, drill 1/2"-deep holes for the pins, which are then cut off flush. Final clamping can be done in the bench vise like the 12"-wide one in the background here, or with clamps.



Drill for 3/8" threaded rod. Use of a jig helps hold the plane body at 45°. A pre-drilled 3/16" hole keeps the 2 1/64" drill on line.

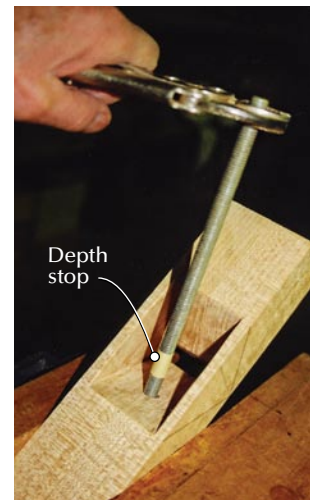

Self-tap. Advance the 3/8" threaded rod to tap the wood into an undersized hole. Tape indicates how far to go.

in each side, and driven into the plane. Cut them off flush. Squeeze the plane in a bench vise or use clamps. Check that all the parts touch the alignment board, and that all the glue lines are tight.

When the glue is dry, sand the top and bottom of the plane body. Keep this sanding minimal to avoid making the box thinner or out of square. Remove any glue beads from the throat. File the front edge of the 45° blade bed slightly to remove the sharp edge. Check the fitting of the blade in the throat opening and correct any irregularities now.

Blade Adjustment Methods

You can choose one of two ways to hold the blade. The time-honored wedge is effective and simple. A wedge 4 1/4" long, cut on a 10° angle, engages a 3/8" dowel pin. This pin has a flat one-third of its thickness where it touches the wedge, and is free to rotate because no glue is used. The photo on page 50 also shows a strike button placed on the fore block. This is 1" of 3/4" hardwood dowel. Glue this piece in a hole to prevent marking the plane when tapping the blade free.

The alternative to a wedge for setting the blade is the double-screw mechanism. The main screw is a 3/8" threaded post and brass knurled thumb nut. The second screw is set into the cap and bears on a rest button set in the blade. This secondary screw is both for adjustment and for holding the blade in use to prevent it from slipping out of adjustment. Using flat-milled blade stock has replaced the traditional forged blades of more than a century ago. Those old blades were wedge-shaped themselves, being thicker at the cutting end. The opposition of two wedges gives positive blade holding, which is now missing from single-piece blades. The rest button and screw rod provide this holding.

Set up some way to hold your plane body at a 45° angle for drilling the screw post. Mark the location of the hole 1 7/8" up from the sole in the center of the blade block. Drill a 3/16" pilot hole to guide the larger 2 1/64" bit; both are drilled to 3/4" deep. File the end of your rod slightly to help it in entering the hole. Spot a mark 3/4" from the end. The rod is held by vise grips while turning. You will

feel the rod hit the bottom the hole. Cut it off leaving 1 1/2" of threaded post – or 1 7/8" if using the 52° pitch adapter. If the post is not square to the block, make it so using a wood block and hammer. If you need to remove the post, use a hacksaw to make a slot for a screwdriver to withdraw it.

There are two shapes in this plane body that are different from a typical plane body. The coffin shape and the step, or raze section, where the handle is bedded defines the Pierce plane. Draw out the shapes, and cut them on your band saw starting with the raze. The upswept end of this cut fits the radius of the 4" x 36" belt sander nicely. The coffin sides are also cut on the band saw followed by sanding a fair curve to the whole body. The edges are chamfered all around for hand comfort. The amount of chamfer along the bottom edge is small, while the top edge has a 1/8" flat to the chamfer increasing where it turns around the nose of the plane.

Blade Cap

Next make the adjustable pressure cap. A production company would have this made as a special casting. What is made here is in keeping with a shop-resourceful project. A piece of hard maple, 3/4" x 2 1/32" x 4", is cut to the profile shown in the drawing. The long bottom bevel, the 15° top angle and the side scallops give it a touch of grace. This cap will be sanded for side-to-side clearance later, the side sanding is determined by how it fits best on the threaded post.

The pressure screw lands on a 5/8" copper washer set into the cap. This is a brake gasket available from an auto store (at NAPA, it's part #26442). A 5/8" recess holds it in place. Start your

Shapes and curves. The profiles are copied from the plans. The coffin shape and handle step define the Pierce plane.

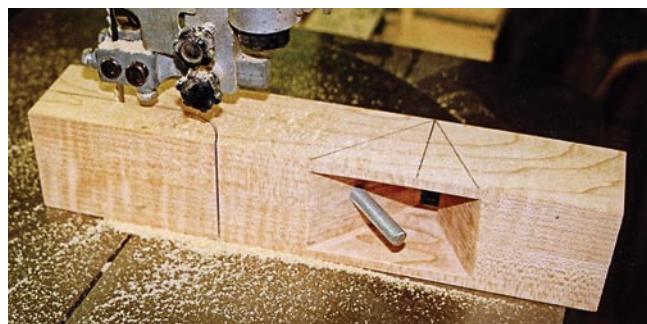
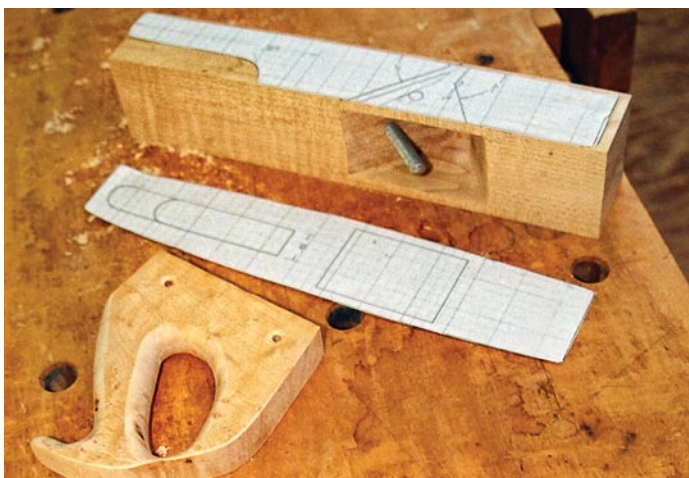

Shape the plane. Cut the raze section and coffin sides on the band saw.



Smooth. Sand both sides and chamfer the edges.

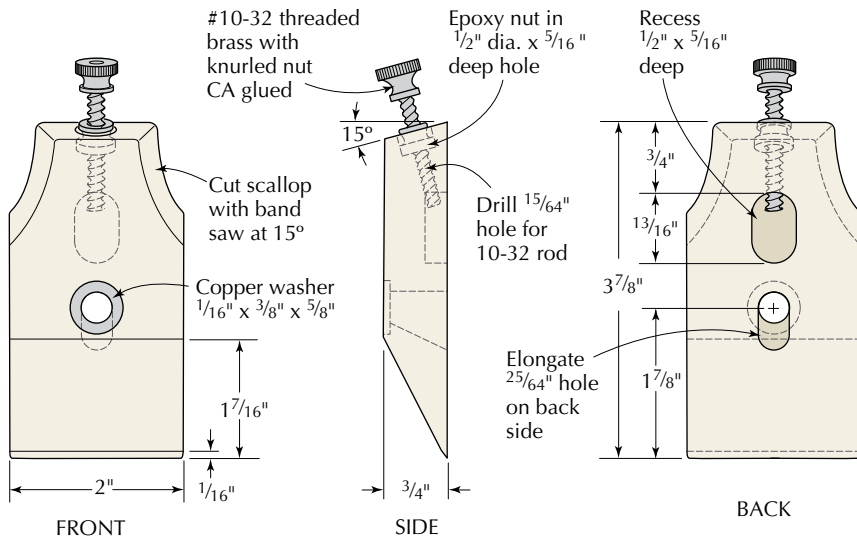

ADJUSTMENT CAP

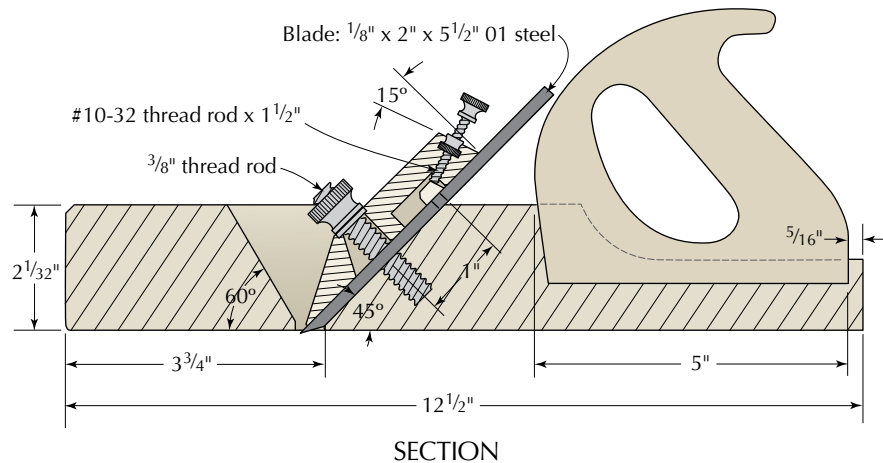

SECTION

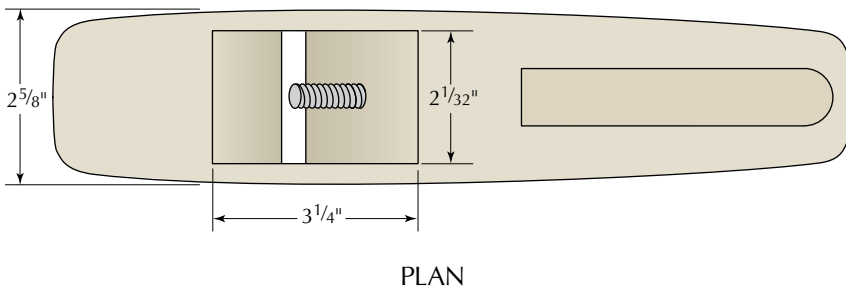

PLAN

Variable-pitch Jack Plane

NO.	ITEM	DIMENSIONS (INCHES)			MATERIAL
		T	W	L	
1	Body	2 1/32	2 1/32	12 1/2	Hardwood
2	Side pieces	5/16	2 1/32	12 1/2	Hardwood
1	Cap	3/4	2 1/32	4	Hardwood
1	Handle	1 5/16	5	5	Hardwood
OPTIONAL PARTS					
1	Wedge	9/16	2	4 1/4	Hardwood
1	Wedge 52° pitch	3/8	2	3	Hardwood

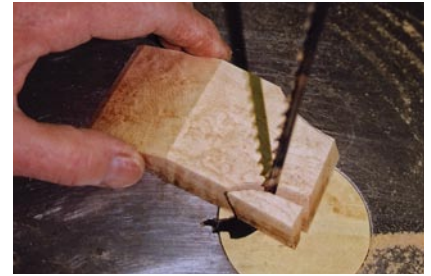

Screw. Cap is sawn and drilled for screw assembly.

drilling with a Forstner bit of this size going only $\frac{1}{16}$ " deep. Next, drill the hole slightly oversized at $\frac{25}{64}$ ". In order to slip on or off the threaded post, this hole must be enlarged. Angle the first hole 30° for post clearance. Follow this with a hole straight into the cap. Finish filing out the hole before setting the copper washer as the last step in setting up your plane.

In the back of the cap, drill a recess for the stud on the blade using a $\frac{1}{2}$ " Forstner bit going $\frac{5}{16}$ " deep. Check the drawing for the location.

The adjustment screw is made from #10–32 steel or brass threaded rod and two knurled brass nuts. One nut is glued to the end of the threaded rod with thread locker or CA glue. The other nut is set into the cap to act as threads

Supplies

Reid Supply

reidsupply.com or 800-253-0421

- 1 ▶ O1 tool steel $\frac{1}{8}$ " x 2" x 18"
#SFS-54006, \$17.66
- 1 ▶ stainless steel rest button, $\frac{1}{2}$ " x $\frac{3}{8}$ "
#PF-105, \$2.79
- 1 ▶ threaded rod, $\frac{3}{8}$ " x 16" x 36"
#TR-90, \$4.16
- 1 ▶ threaded rod, 10-32, 36" x 36"
#TR-57, \$8.39
- 1* ▶ brass thumb nut, $\frac{3}{8}$ " x 16"
#AJ-727, \$3.12
- 2 ▶ brass thumb nuts, 10-32
#AJ-718, \$1.68 ea.

*2 needed for making beveled washer

Any AutomotiveSupply Store

- 1 ▶ brake gasket copper washer
 $\frac{5}{8}$ " dia.; must accept $\frac{3}{16}$ " rod

Prices correct at time of publication.



Two-screw mechanism. Drilling the top screw at 15° will hold the inverted thumb nut. The back of the cap has space for the rest button and a 3/8" lead screw hole. The front of the cap has wear washer and adjustment rod.

in the hole. Hold the cap at a 15° angle to the bit in your drill press. Start with a 1/2" Forstner bit and drill 5/16" deep. Drill the remainder of the hole with a 15/64" bit. Press a nut, knurled side first, into the hole. To ensure that you have things lined up properly, thread the rod into the nut before gluing. Use a small amount of epoxy or thick CA glue to fill the recess around the nut.

The Handle

The handle completes the raze and coffin-shaped body. The shape of the handle is personal, and relates to your hand size and how you grip the plane.

The raze stepped-down handle improves the feel and control of the plane over the style where the handle

Brass washer made from 3/8" knurled nut; remove threads, file to angle for landing of main screw

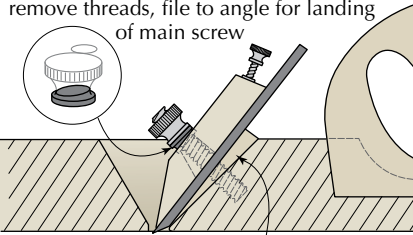

Wood wedge 2" x 3", angled from thin at bottom to 3/8" at top; drill 3/8" hole for post

52° PITCH OF BLADE

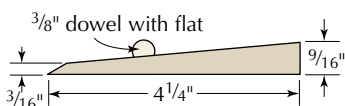

ALTERNATIVE
BLADE-HOLDING WEDGE



Handle. The handle is cut out and routed for curves. The two screws holding the handle for this operation are in the bottom edge that will be cut off.

is mounted higher on a square plane body. The handle itself is cut from 7/8" or 15/16" maple. The latter dimension is what hardwood boards are dimensioned when milled "hit or miss" for furniture work. It is sold this way as a more uniform dimension than 4/4 rough stock. Whatever you have, cut the profile and hole (see the photo above). The top faces are left flat, while the hand-grip surfaces need to be rounded over.

The handle is bedded 3/8" deep into a rectangular slot.

Final Details

A cluster of chores remain to finish your plane. With the blade-adjustment mechanism done, check the throat opening. Sand the side of the cap to give the needed clearance. File the hole for the post likewise to allow taking it on or off. Press the copper washer into place. Now sharpen the blade. Seeing that everything works properly will take some fine-tuning.

The maker's mark goes on the top of the iron and the nose of the plane. I like to date it as well. The plane body is protected with a thin sealer of varnish. The brass adjustment screw may need to be

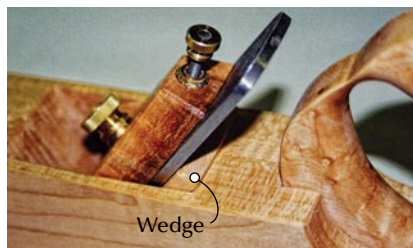

Smoothing plane option. Here's a cap assembly with a 52° wedge that allows the standard 45° pitch to be changed to a smoothing plane.



Fine-tuning. Sharpen the blade, make the blade square to sole and adjust the cap.

slightly stiffened with a swipe of candle wax or beeswax to prevent it from inadvertently moving, and not doing its job as a stop for holding the blade.

It is possible to adjust the angle of the blade to the 52° pitch of a smoothing plane. Cut a wedge 2" wide and 3" long with the thickness 3/8" at the top and tapered to a sharp edge where it meets the throat opening. A 3/8" hole corresponding to the position of the 3/8" threaded post will allow the wedge to go between the blade and the block. The length of the post needs to be longer by 3/8". Also, the knurled brass nut meets the cap at a new angle. A wedged brass washer is made from the small side of a 3/8" knurled nut. First file out the threads, then saw off the small milled section on an angle and file to proper size to make a landing for the nut.

Remember those other lengths of material – the O1 steel and threaded rod along with the extra knurled nuts and studs ordered at the beginning? Making planes could be catching. **PWM**

John founded and runs The Home Shop, where he teaches woodworking classes, and makes and sells Shaker box materials (ShakerOvalBox.com).

Go Online FOR MORE ...

For links to all these online extras, go to:
► popularwoodworking.com/apr11

VIDEO: Watch a short video that shows this plane in use.

ARTICLE: Read a profile of John Wilson and tour his shop.

WEB SITE: Discover John Wilson's The Home Shop.

TO BUY: "The Perfect Edge" by Ron Hock – a great book on sharpening.

IN OUR STORE: Handplane Basics DVD.

Our products are available online at:

► ShopWoodworking.com